

SPECIFICATIONS:

MATERIALS:

HOUSING: PBT, UL94 V-0, BLACK
 CONTACTS: GOLD PLATED BRASS (SEE P/N KEY BELOW)
 NUT: (SEE P/N KEY BELOW)
 SHELL: (SEE P/N KEY BELOW)
 ORING: EPDM

ELECTRICAL:

RATED CURRENT: 1.5A
 RATED VOLTAGE: 30V
 INSULATION RESISTANCE: 100 MOhms MIN.
 CONTACT RESISTANCE: 10 mOhms MAX.

ENVIRONMENT:

OPERATING TEMPERATURE: -40°C TO +85°C
 WATER PROOF: IP67

MAX WIRE AWG: 26

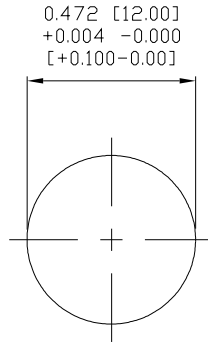

PANEL CUTOUT

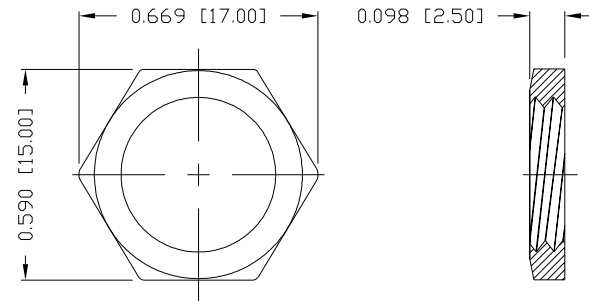

NUT

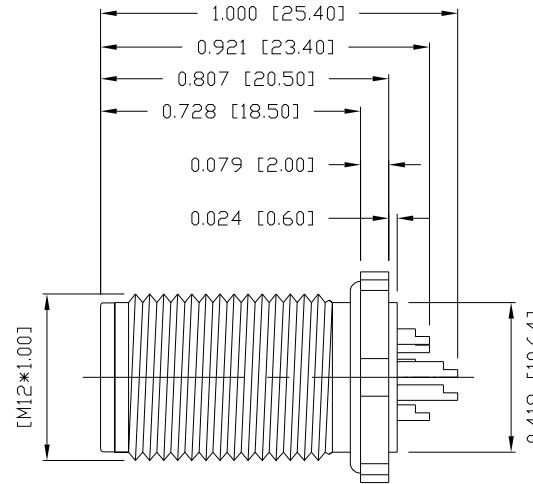
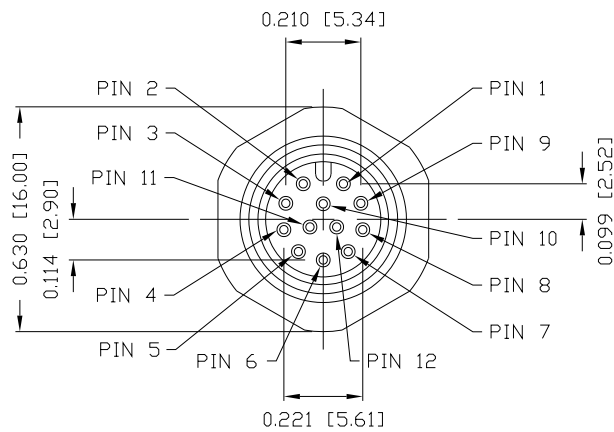

859-012-103R00Y

3 = BRASS/NICKEL SHELL & NUT
 S = STAINLESS STEEL SHELL & NUT

1 = GOLD FLASH
 4 = 10µ" GOLD

Full stainless steel variant successfully passes 96-hour salt spray testing per ASTM B117

RoHS COMPLIANT

UNITS = inch [mm]

DO NOT SCALE FROM DRAWING



THESE DRAWINGS AND SPECIFICATIONS ARE THE PROPERTY OF NorComp AND SHALL NOT BE REPRODUCED, COPIED OR USED AS THE BASIS FOR THE MANUFACTURE OR SALE OF APPARATUS WITHOUT WRITTEN PERMISSION.

DRAWN: M. SIGMON

DATE: 03/08/2016

NorComp

SCALE: NTS	SHEET 1 OF 1	REV 4
------------	--------------	-------

DWG NO. 859-012-103R00Y