

DESCRIPTION: USB TYPE "B", VERTICAL, SINGLE DECK

**MATERIALS:**

- SHELL: COPPER ALLOY, NICKEL PLATED
- INSULATOR: THERMOPLASTIC
- CONTACTS: COPPER ALLOY
- 30u" GOLD PLATED ON CONTACT AREA
- TIN ON TAIL END

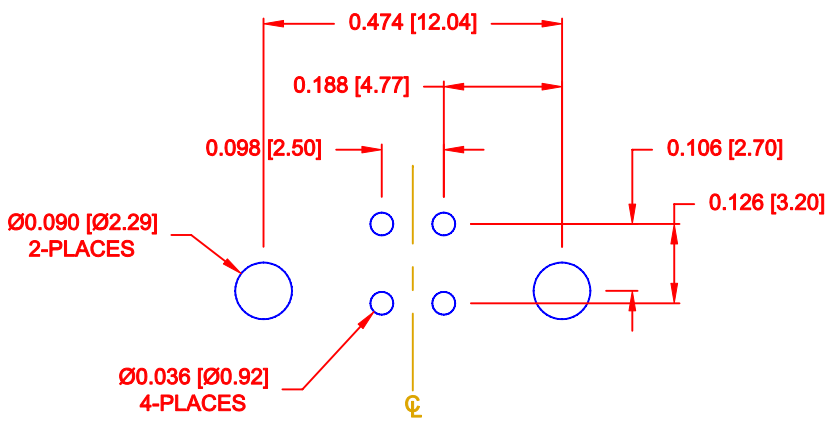
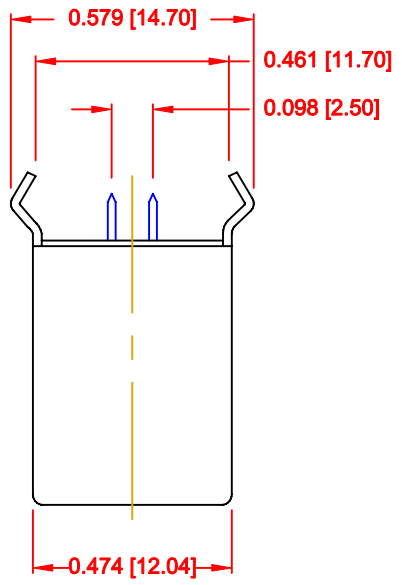

**RECOMMENDED PCB LAYOUT**  
SCALE = 3 : 1

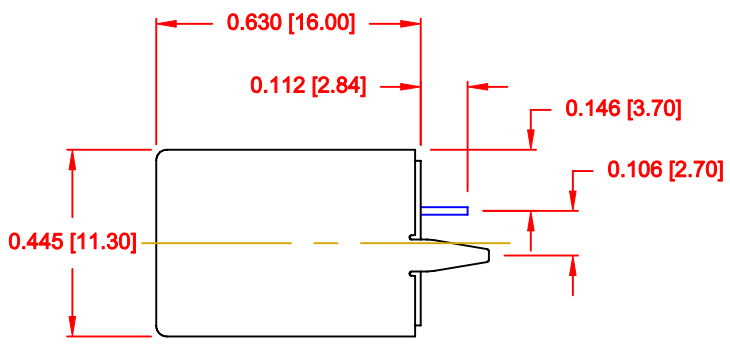
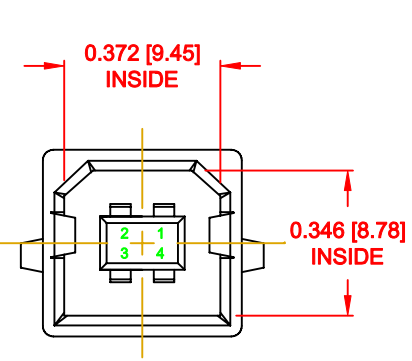

**DO NOT SCALE FROM DRAWING**

	THESE DRAWINGS AND SPECIFICATIONS ARE THE PROPERTY OF NorComp AND SHALL NOT BE REPRODUCED, COPIED OR USED AS THE BASIS FOR THE MANUFACTURE OR SALE OF APPARATUS WITHOUT WRITTEN PERMISSION.		DRAWN: <b>C. SMITH</b>	DATE: <b>02-03-10</b>
			CHECKED:	DATE:
<b>NorComp</b>	SCALE: <b>2 : 1</b>	SHEET <b>1</b>	OF <b>1</b>	REV <b>0</b>
	DWG NO. <b>061-004-121R010</b>			

**RoHS COMPLIANT**