

DESCRIPTION: POWER - SOLDER CUP - MALE

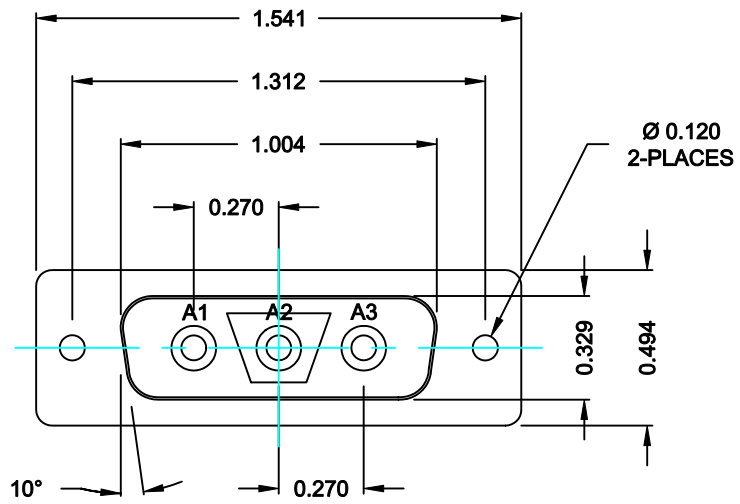

SPECIFICATIONS:

ELECTRICAL:
 INSULATOR RESISTANCE: 5,000 MegOHMS Min.
 DIELECTRIC WITHSTANDING: 1,000VAC r.m.s.
 OPERATING TEMPERATURE: -55° C ~ +125° C
 CONTACT RESISTANCE: 30 MilliOHMS Max.
 POWER PINS: SEE PART No. BELOW

MECHANICAL:
 CONTACT INSERTION FORCE: 4.5 Kg Max.
 CONTACT SEPARATOR FORCE: 0.3Kg Min.

MATERIALS:
 CONTACTS: BRASS
 INSULATOR: PBT UL94V-0 RATED, 230°C PROCESS TEMP.
 SHELL: STEEL

FINISH:
 SHELL: NICKEL

6803W3K103LYY1

20 = 20 AMPS
 40 = 40 AMPS

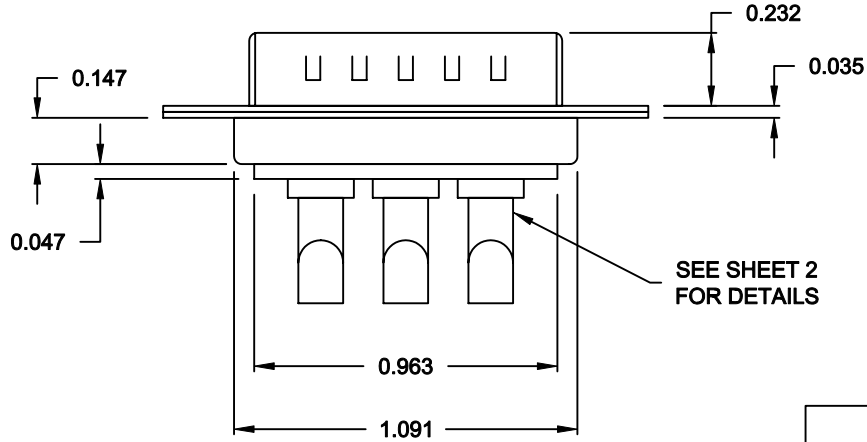

RoHS COMPLIANT

	THESE DRAWINGS AND SPECIFICATIONS ARE THE PROPERTY OF NorComp AND SHALL NOT BE REPRODUCED, COPIED OR USED AS THE BASIS FOR THE MANUFACTURE OF SALE OF APPARATUS WITHOUT WRITTEN PERMISSION.		DRAWN: C. SMITH	DATE: 09-11-06
	CHECKED: X		DATE: X	
NorComp	SCALE: N.T.S.	SHEET 1 OF 2	REV 0	
	DWG NO. 6803W3K103LYY1			

DESCRIPTION: 680 SERIES CONTACTS

NOTE:
POWER CONTACTS COME
PRE-LOADED INTO INSULATORS

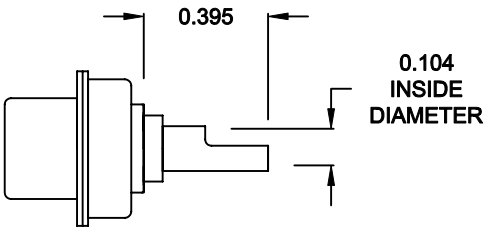

20 AMP POWER CONTACTS
ACCEPTS UP TO 12 AWG WIRE

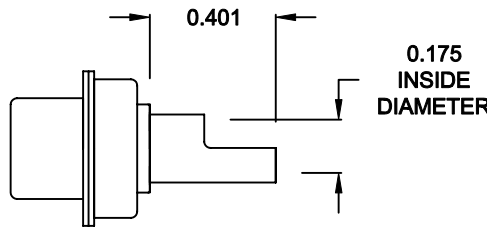

40 AMP POWER CONTACTS
ACCEPTS UP TO 8 AWG WIRE

RoHS COMPLIANT

	THESE DRAWINGS AND SPECIFICATIONS ARE THE PROPERTY OF NorComp AND SHALL NOT BE REPRODUCED, COPIED OR USED AS THE BASIS FOR THE MANUFACTURE OF SALE OF APPARATUS WITHOUT WRITTEN PERMISSION.	DRAWN: C. SMITH	DATE: 09-11-06
		CHECKED: X	DATE: X
<h1>NorComp</h1>	SCALE: N.T.S.	SHEET 2 OF 2	REV 0
	DWG NO. 6803W3K103LYY1		