

1. CONNECTOR 1 : 854-003-203RLS4, MOLDED STRAIGHT HOOD, COLOR BLACK
2. WIRE : 26AWG, 2 1/2 TWISTED PAIRS, UL20276, FOIL/BRAID/DRAIN SHIELD, COLOR BLACK, 30V
3. SHIELDING : 360°
4. CABLE DIAMETER : 4.60mm±0.15mm
5. PIN OUT :

WIRING SCHEMATIC

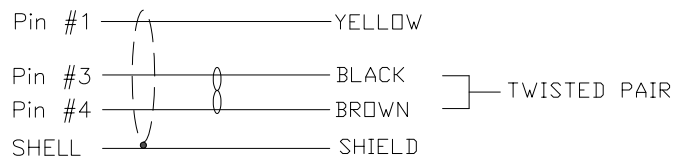

CCA-000-MYYR207

- 01 = 1 METER ±12.00mm
- 02 = 2 METERS ±25.00mm
- 03 = 3 METERS ±25.00mm

\*\*SEE PAGE 3 FOR CABLE SPECIFICATIONS

**RoHS COMPLIANT**

UNITS = mm

DO NOT SCALE FROM DRAWING

	THESE DRAWINGS AND SPECIFICATIONS ARE THE PROPERTY OF NorComp AND SHALL NOT BE REPRODUCED, COPIED OR USED AS THE BASIS FOR THE MANUFACTURE OR SALE OF APPARATUS WITHOUT WRITTEN PERMISSION.	DRAWN:	DATE:	<b>NorComp</b>	SCALE:	SHEET OF	REV
		M. SIGMON	04-14-15		NTS	1 3	5
					DWG NO.	<b>CCA-000-MYYR207</b>	

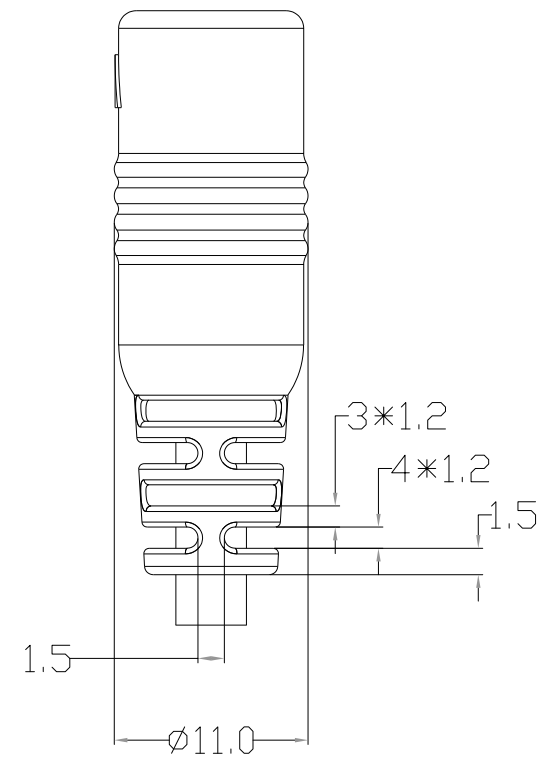
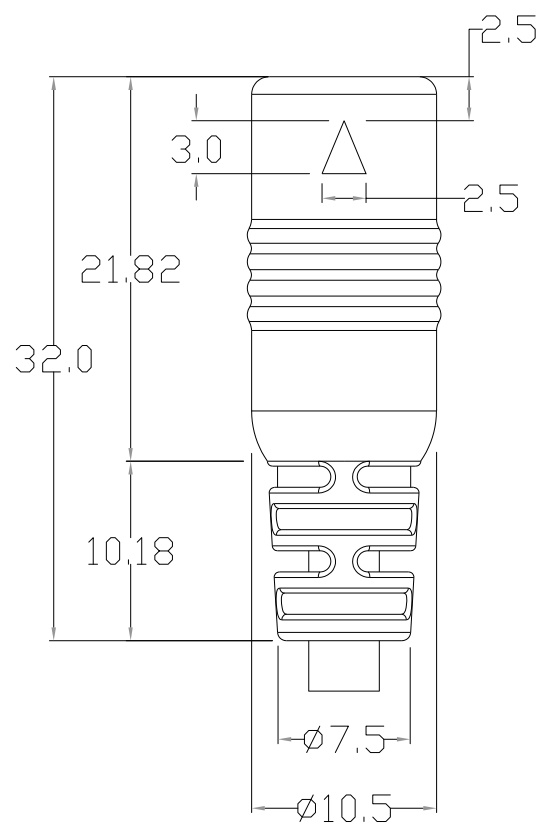

RoHS COMPLIANT

UNITS = mm

DO NOT SCALE FROM DRAWING



THESE DRAWINGS AND SPECIFICATIONS ARE THE PROPERTY OF NorComp AND SHALL NOT BE REPRODUCED, COPIED OR USED AS THE BASIS FOR THE MANUFACTURE OR SALE OF APPARATUS WITHOUT WRITTEN PERMISSION.

DRAWN: M. SIGMON

DATE: 04-14-15

NorComp

SCALE: NTS

SHEET 2 OF 3

REV 5

DWG NO. CCA-000-MYYR207

ELECTRICAL CHARACTERISTICS

VOLTAGE RATING : 30V  
 TEMPERATURE RATING : 80°C  
 SPARK TEST : AC-500V/0.15 sec MIN.  
 DIELECTRIC STRENGTH : AC-750V/1 sec MIN.  
 INSULATION RESISTANCE : SR-PVC: DC-500V 10 MOHM/KM MIN. AT 20°C  
 CONDUCTOR RESISTANCE : 26AWG-153 OHM/KM MAX. AT 25°C

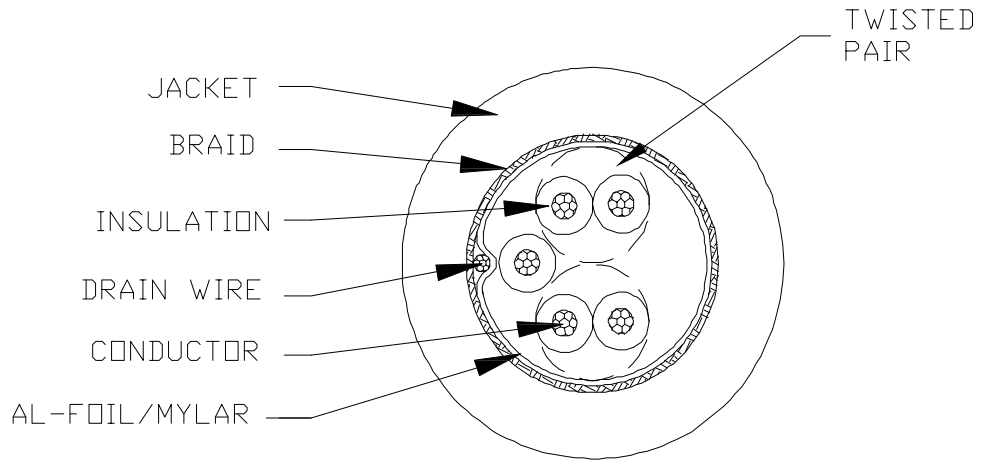

COLOR CODE

1. BLACK \* BROWN (P570 & P571)
2. RED \* ORANGE (P572 & P573)
3. YELLOW (574)

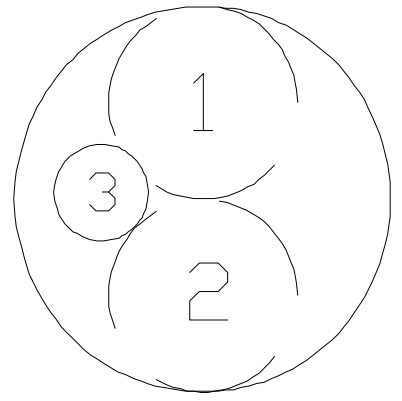

RoHS COMPLIANT

DO NOT SCALE FROM DRAWING

	THESE DRAWINGS AND SPECIFICATIONS ARE THE PROPERTY OF NorComp AND SHALL NOT BE REPRODUCED, COPIED OR USED AS THE BASIS FOR THE MANUFACTURE OR SALE OF APPARATUS WITHOUT WRITTEN PERMISSION.	DRAWN:	DATE:	<h1>NorComp</h1>	SCALE:	SHEET	OF	REV
		M. SIGMON	04-14-15		NTS	3	3	5
					DWG NO.	CCA-000-MYYR207		