

ASSEMBLY INSTRUCTIONS:

1. PREPARE CABLE ENDS, CONNECT TO CONNECTOR
2. SELECT CORRECT INSERT SIZE FOR CABLE BEING USED, PLACE LONG INSERT INTO RECESS AREA OF BASE HOOD
3. PLACE SHORT INSERT INTO RECESS OF COVER HOOD
4. PLACE CABLE INTO INSERT IN BASE HOOD. USING EITHER THE FLAT OR CURVED STRAIN RELIEF (OR BOTH), CLAMP THE CABLE MAKING SURE THE JACKET IS BELOW THE STRAIN RELIEF
5. IF CABLE IS SHIELDED, FOLD SHIELD AND/OR GROUND WIRE BACK UNDER STRAIN RELIEF. CUT OFF ANY EXCESS WIRE SO IT DOES NOT STICK OUT OF THE STRAIN RELIEF
6. PLACE THE THUMBSCREWS INTO THE BASE HOOD
7. PLACE THE COVER HOOD ON TOP OF THE BASE HOOD, MAKING SURE NO WIRES ARE PINCHED
8. HOLDING THE HOODS TOGETHER, SCREW THE TWO HOOD SECTIONS TOGETHER USING THE SCREWS PROVIDED

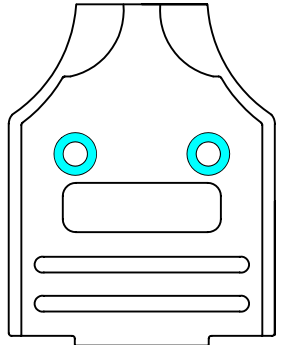

COVER HOOD

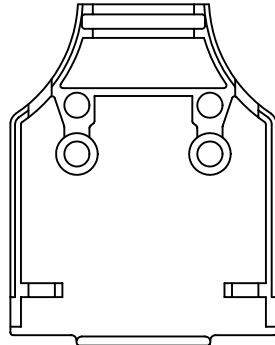

BASE HOOD

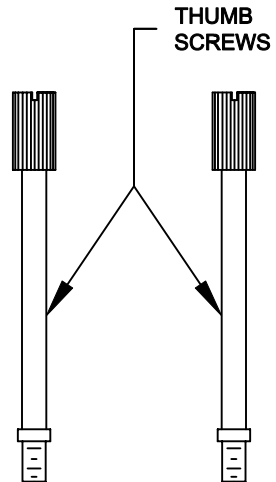

THUMB SCREWS

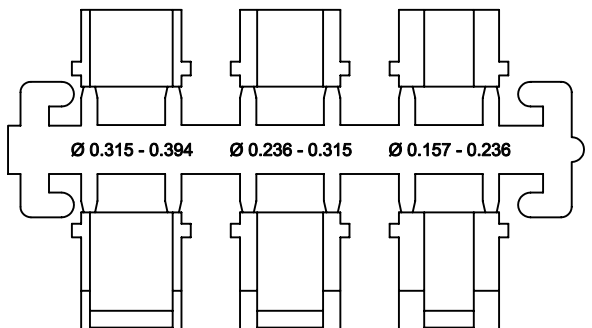

METALIZED PLASTIC INSERTS

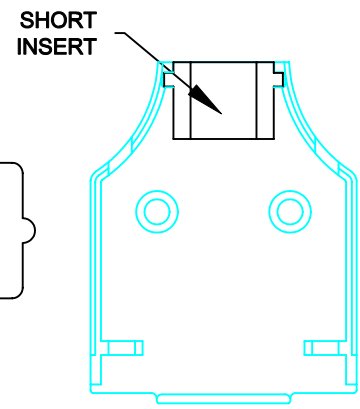

ITEM No. 3

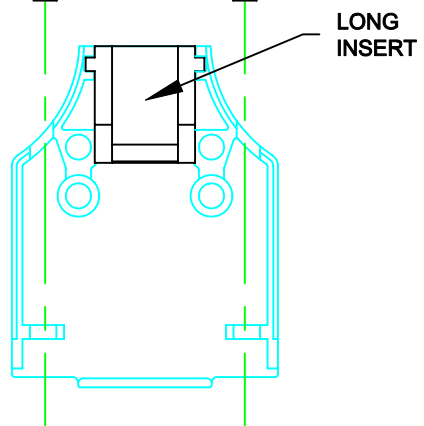

ITEM No. 2 & 6

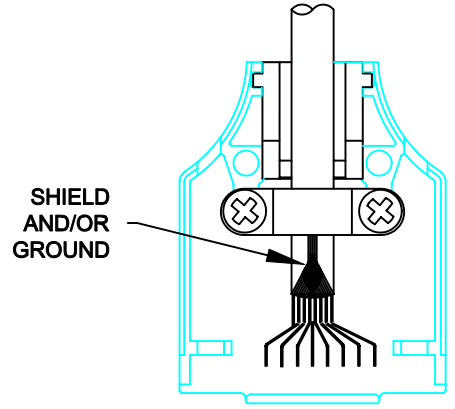

ITEM No. 4 & 5

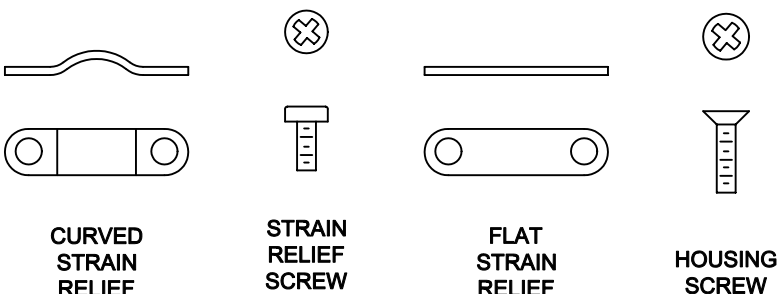

CURVED STRAIN RELIEF

STRAIN RELIEF SCREW

FLAT STRAIN RELIEF

HOUSING SCREW

RoHS COMPLIANT

DIE CAST

	THESE DRAWINGS AND SPECIFICATIONS ARE THE PROPERTY OF NorComp AND SHALL NOT BE REPRODUCED, COPIED OR USED AS THE BASIS FOR THE MANUFACTURE OF SALE OF APPARATUS WITHOUT WRITTEN PERMISSION.		DRAWN: C. SMITH	DATE: 03-28-07
			CHECKED:	DATE:
NorComp		SCALE: N.T.S.	SHEET 1	OF 1
		DWG NO. BACKSHELL - 952 SERIES		REV 0